

# FOREST

DRAPERY HARDWARE

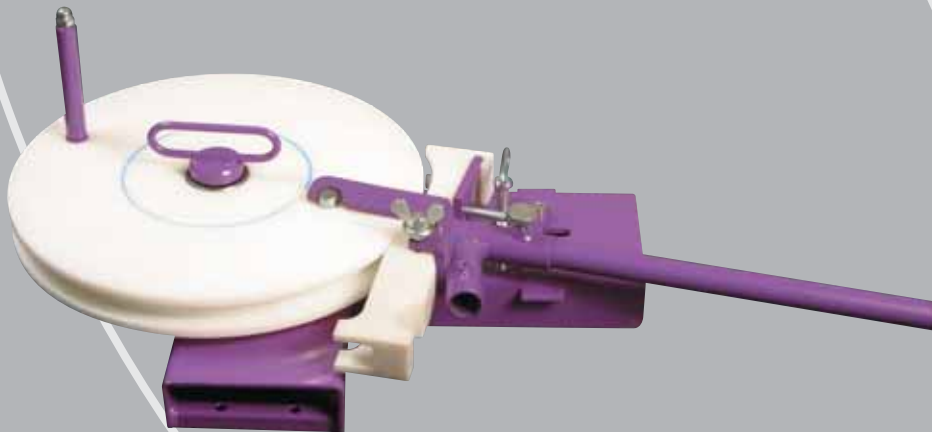
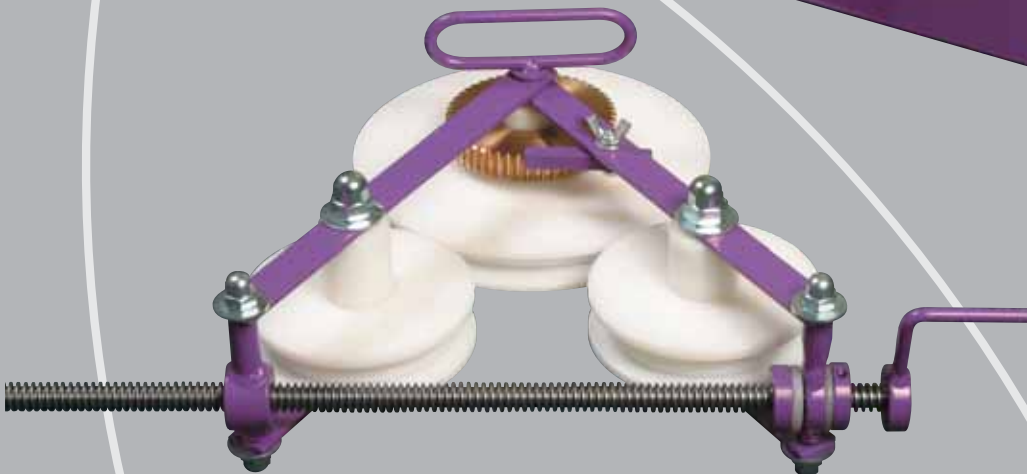

**Bending Instructions**

# Instructions Compact Bending Tool for KS® CKS® DS® and CRS® 20mm

- (A) Bending Strip
- (B) Guide Wedge (art nr: 9510000015)
- (C) Bending Dye (4" radius)
- (D) Metal Dye
- (E) Metal Housing
- (F) Measurement Line
- (G) Holder with Metal Protractor
- (H) Handle
- (K) Arrow
- (L) KS Removable Inside Bending Strip (art nr: 9510000012)

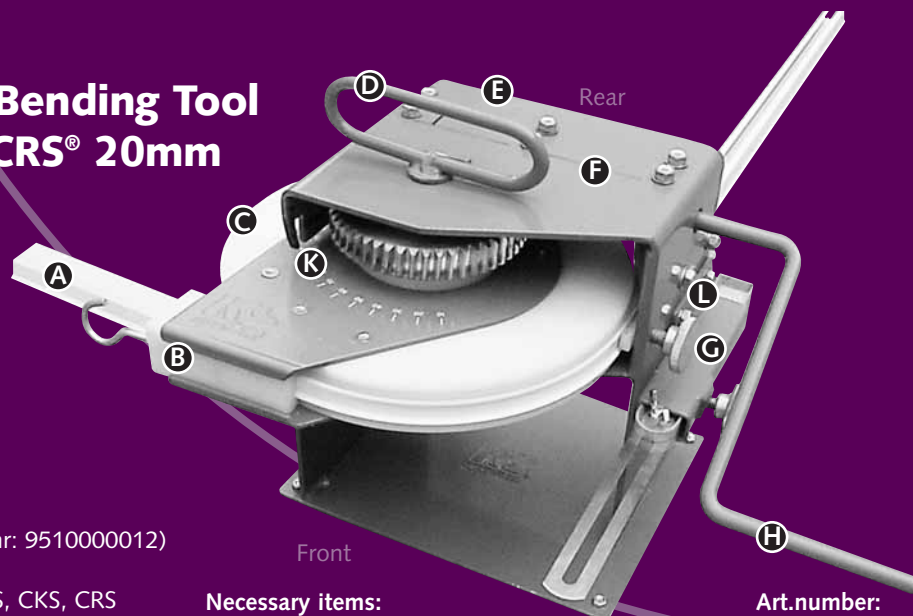

Forest developed one Bending House for: KS, CKS, CRS 20 mm and DS. Depending on the type of track that has to be curved a All-in Bending Wheel can be ordered. Remark: for bending of the CKS track you will need to order the CKS Bending Strip, KS Bending Wheel all-in and a Bending House.

### Necessary items:

|  |                        |
|--|------------------------|
| KS/DS/CRS Bending House                                    | Art.number: 1050000000 |
| KS Bending Wheel all-in (incl KS 60 cm bending strip)      | 1050100000             |
| DS Bending Wheel Set all-in (incl DS 60 cm bending strips) | 2050000000             |
| CRS Bending Wheel 20 mm all-in (incl CRS 60 cm strips)     | 5860000020             |
| CKS Bending Strip Compact                                  | 1560100000             |

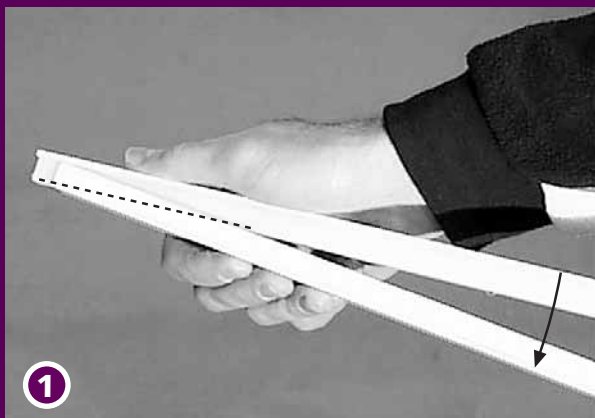

1 Press Bending Strip (A) into slot of the track, where you want to make a curve. Do not slide the strip in: this reduces the lifetime of the nylon strip.

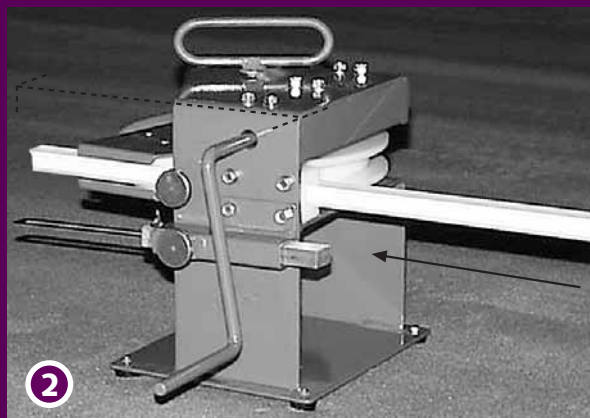

2 Insert the KS-track through the backside of the Compact Bending tool. To make a right hand curve, insert the track with the slot side up. To make a left hand or reversed curve, insert the track with the slot side down.

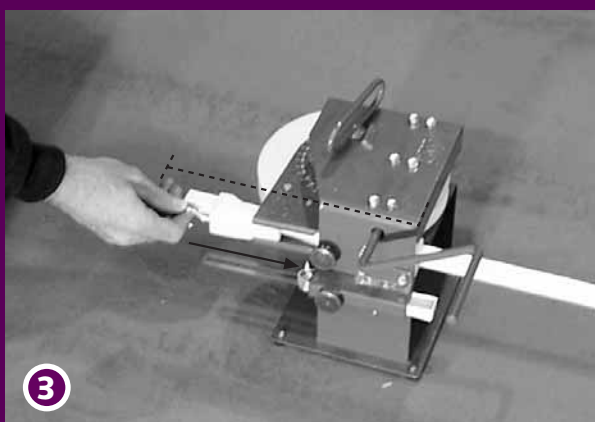

3 Insert the Guide-Wedge (B) firmly into the place between the metal part of the Bending Dye (C) and the track to position the track in the right place. Take the measurement of the first curve from the end of the Metal House (E) to the end of the track. This will create the distance from the outside of the track to the wall. Start curving by turning the handle (H) clockwise.

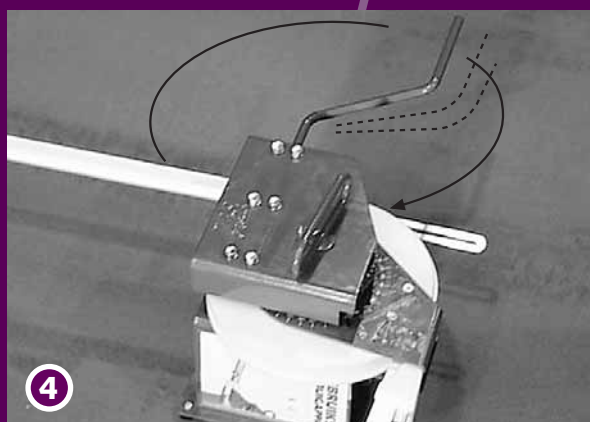

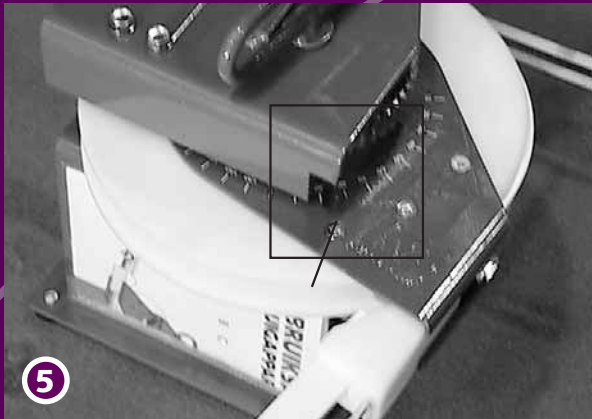

5  
Continue until the required angle has been reached. The Arrow (K) points exactly to the required angle on the scale divider. Turn a few degrees more to avoid spring back of the aluminium track.

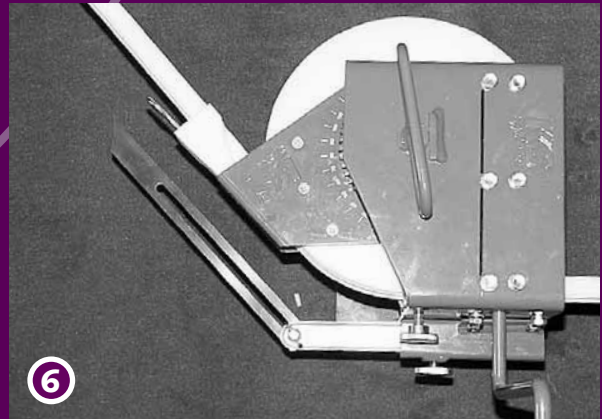

6  
When angle is unknown, use the Metal Protractor (G) and place it against wall or on mal.



7  
When the required curve is made, turn the handle (H) a few times anti-clockwise to release tension. Then, remove the Guide-Wedge, Metal Pin (D) and slide-out the Bending Dye from the Metal Housing, together with the track.

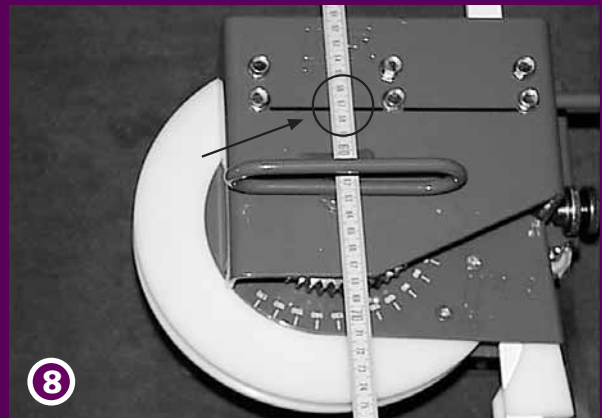

8  
The Measurement Line (F) will be used for the exact measurement determination of the second curve.

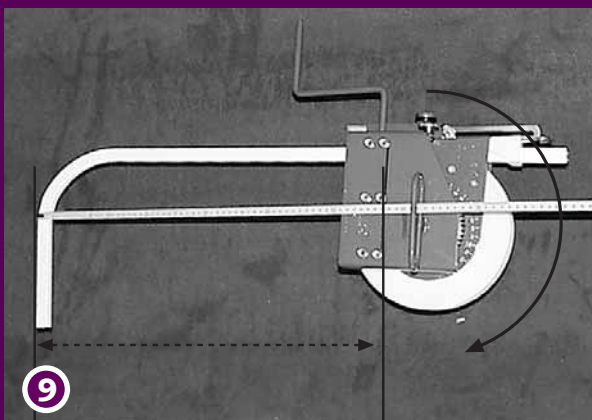

9  
To make a second curve of 90° in the same KS-track, use a tape measure from the outside of the track to the measurement line. This will create the distance from outside to outside of the two curves.

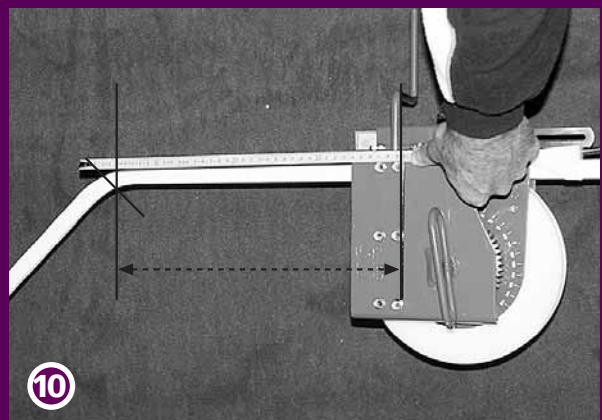

10  
For curves, other than 90°, use a reference point in the middle of the first curve. For the second curve, use the Measurement Line. This will create the distance from center to center of the two curves.

Same instructions can be used for bending DS®. Only, use the DS Compact Bending tool (art.number: 2060000000) with the DS bending strip (art.number: 2060100000), CKS and CRS.

# Instructions for the Continuous Curver for KS® and CKS®

- (A) Bending dyes small
- (B) Bending dye large
- (C) Metal pin
- (D) Unit stabilizer
- (E) Handle

## Necessary items:

KS/DS/CRS Bending House  
 Continuous Curver  
 Replacement Bending Strip  
 KS - 7 m (10')  
 Replacement Bending Strip  
 CKS - 7 m (10')

Art.number:  
 1050000000  
 1060200000  
 1060300000  
 1560300000

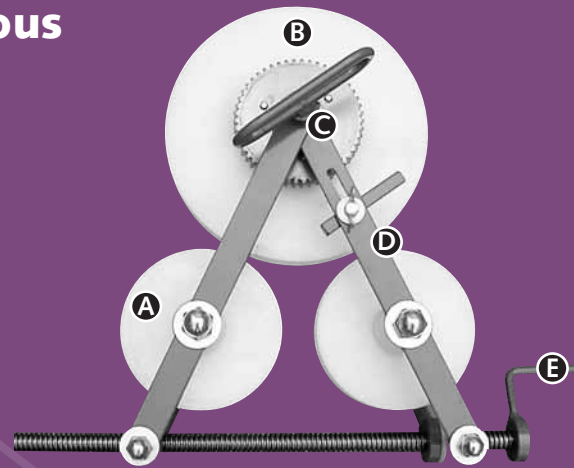

The Continuous Curver can be used when curves with a radius other than 10 cm (4") have to be made, like bay windows, arches, bows and circles. When using this option frequently, consider the purchase of the Electric Bending Machine.



1 Remove the Metal Pin (C) and the regular bending dye from the Compact Bending tool. Insert the Continuous Curver with the unit Stabilizer (D), so that slack between the Small Bending Dyes (A) and the Compact Bending tool will be avoided.



2 For determining necessary track length  $3,14 \times$  diameter of the circle. Add 10 cm (4") more on both ends. Insert the bending strip into the track. Place the track between the Bending Dyes (A and B) with its slot facing up to make a right hand curve, or down to make a left hand curve. Turn the small handle (E) a few times to avoid slack.



3 Mark the distance to be bent with reference points on the track. Turn the Small Handle (E) a maximum time of five turns. Start turning the big handle of the Compact Bending tool to bend the track through the Continuous Curver.

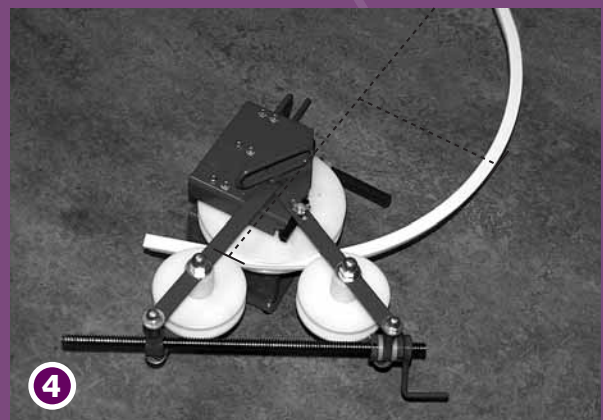

4 Run the whole distance to be bent through the Continuous Curver until the reference points hit the first Small Bending Dye (A), each time. The radius needs to be checked frequently. If the radius is still not achieved, turn the Small Handle a few times more. Repeat this, until the required radius is created. It is possible to reverse the curve, once the radius is overbent.

# Instructions CS, CCS, MTS, FMS and CRS 28mm Bending Tool

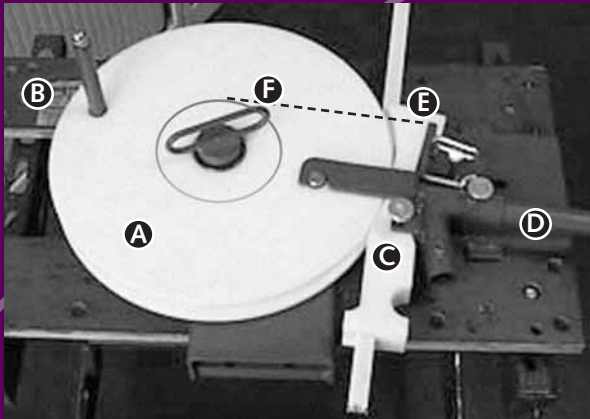

- (A) Bending Dye
- (B) Tab
- (C) Guide Wedge
- (D) Handle
- (E) Bending House
- (F) Measurement Line

Forest developed one Bending House for: CS/CCS/FMS, MTS and CRS 20 and 28 mm (0,8" and 1,1"). Depending on the type of track that has to be curved an All-in Bending Wheel can be ordered.

| Necessary items:                                 | Art.number: |
|--|-------------|
| Contract Bending Tool Basic                      | 2560000000  |
| MTS Bending Wheel all-in (incl 90cm strip)       | 4560000000  |
| CRS Bending Wheel 28 mm all-in (incl 90cm strip) | 5860000028  |
| Extended Lever                                   | 9525000015  |
| To be used for bending of MTS and CRS 28 mm      |             |

|  |            |
|--|------------|
| CS/CCS/FMS Bending Wheel (excl strip!)           | 2561000000 |
| The Bending Strips have to be ordered separately |            |
| CS Set Bending Strips                            | 2560100000 |
| CCS Set Bending Strips                           | 3060100000 |
| FMS/TCS Set Bending Strips                       | 5160100000 |
| CRS Contract Bending Wheel 20 mm all-in          | 5860200020 |

Continuous curves can be made with the Electric Powered Bender (not displayed here).

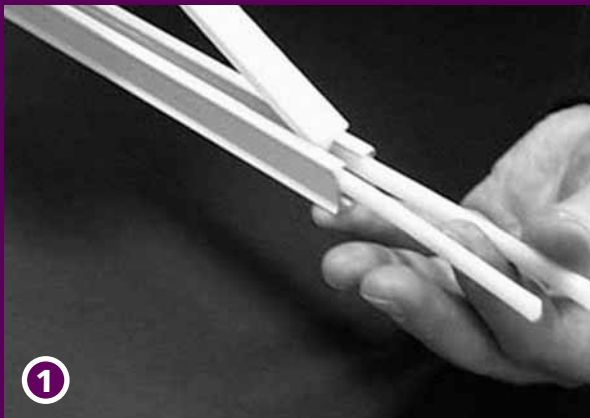

1 First, insert the two smaller bending strips into the track. Then, press the bigger bending strip into the slot of the track between the smaller ones.



2 Insert the track from the backside of the Bending tool, between the Bending Dye (A) and the Bending House (E). Place the handle (D).

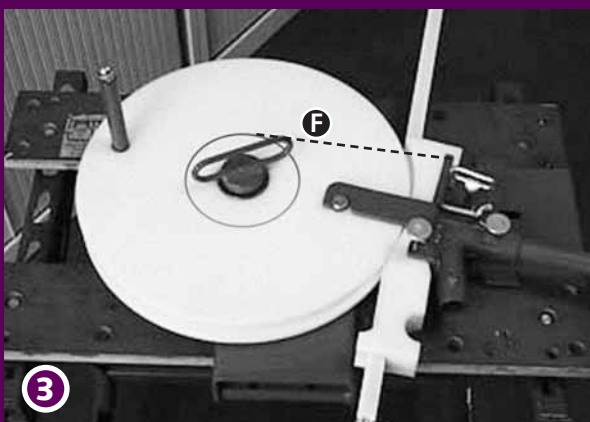

3 Place the Guide-Wedge (C) as depicted on the foto. Slide the track in position and determine the required size from the measurement line (F) to the end of the track. This will create the distance from the outside of the track to the wall.



4 Tighten the screw on the Guide-Wedge. Start bending by turning the handle until the required angle is reached. For two curves in one track, measure from the outside of the track to the measurement line (F). This will create the distance from the outside of the track between the two curves.

This is an example of bending a bay window with one track: KS®, CKS®, DS®, CRS® 20mm

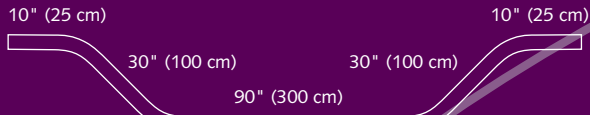

1

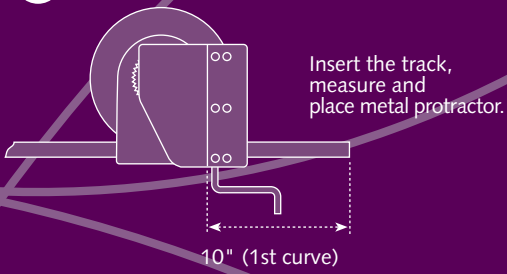

2

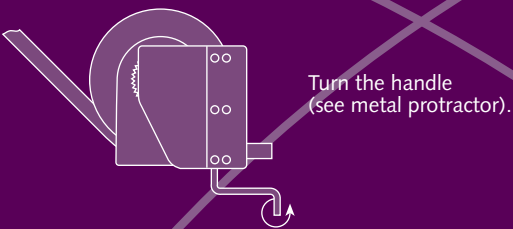

3

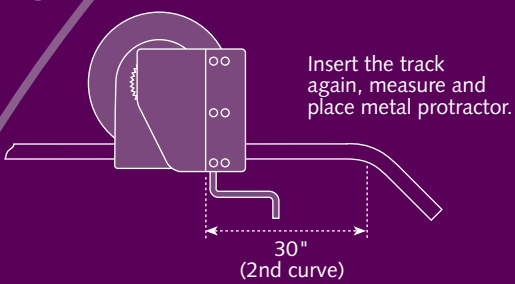

4

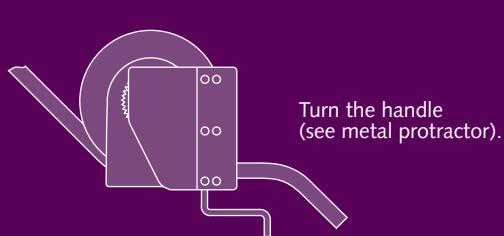

5

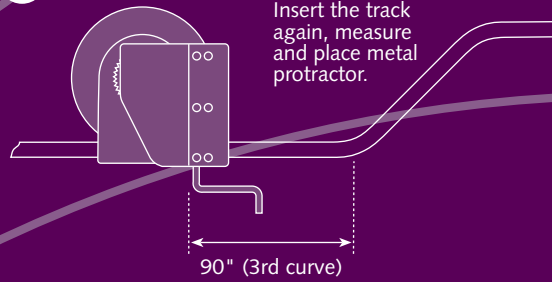

6

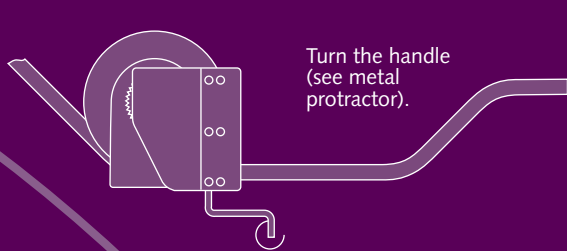

7

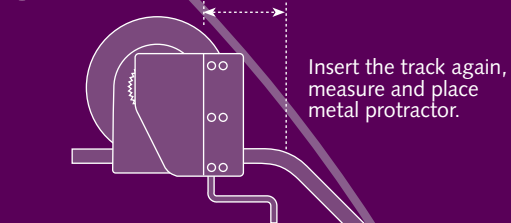

8

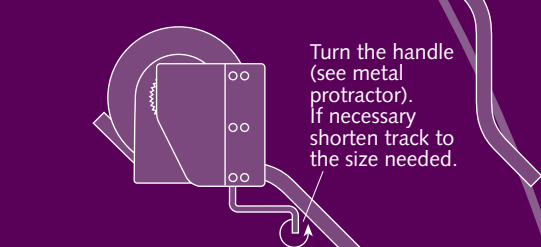

**FOREST**  
DRAPERY HARDWARE